

90060133 IT-FR



via Arcevese, 44
60010 Casine di Ostra, Italy
T +39 071 688771
F +39 071 688586
export@messersi.it
www.messersi.it

ad'acent

Trasportatori cingolati
Transporteurs à chenilles

UTILITY LINE

TC45
TC50
TC50d
TC80
TC85
TC85d



 **MESSERSI** spa

 **MESSERSI** spa

caratteristiche generali

caractéristiques générales

Trasportatore cingolato con sottocarro con cingoli in gomma, trasmissione idraulica a comando manuale con pompa tripla ad ingranaggi e motori orbitali a cilindrata fissa. Sterzata tramite rotazione indipendente dei cingoli. Sistema di raffreddamento ad aria forzata brevettato.

Transporteurs à chenilles en caoutchouc avec transmission hydraulique à commande manuelle avec pompe triple à engrenages et moteurs orbitaux à cylindrée fixe. Braquage effectué par la rotation indépendante des chenilles. Système de refroidissement par air forcé breveté.

Seconda velocità di traslazione tramite apposita leva sul distributore oleodinamico. Presa di forza P.T.O. a doppio effetto optional (non disponibile per TC45, TC50 e TC50d) per l'utilizzo di utensili ausiliari di portata mx 20 lt/min e pressione di 150 bar. Altre portate/pressioni sono disponibili su specifica richiesta. Sottocarro cingolato utilizzabile per applicazioni specifiche. Deuxième vitesse de translation par levier sur le distributeur oléodynamique. Prise de force P.T.O. hydraulique à double effet en option (pas disponible pour TC45, TC50 et TC50d) avec débit max. de 20 lt/min et pression 150 bar. Disponibles différents débit/pressions hydrauliques selon demande spécifique. Base à chenilles à utiliser pour applications particulières.

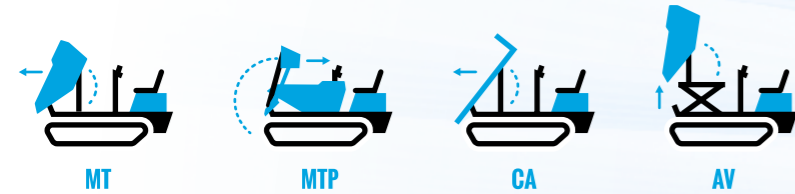

dati tecnici

données techniques

		MT - MTP					CA					AV						
		TC45	TC50	TC50d	TC80	TC85	TC85d	TC45	TC50	TC50d	TC80	TC85	TC85d	TC45	TC50	TC50d	TC80	TC85
Capacità di carico - colmo à comble * SAE Standard - raso à ras * SAE Standard - liquidi liquides	m³ m³ m³	0,30 0,26 0,18	0,30 0,26 0,18	0,30 0,26 0,18	0,38 0,32 0,12	0,38 0,32 0,12	0,22 0,22 -	0,22 0,18 -	0,22 0,18 -	0,30 0,28 -	0,30 0,28 -	0,30 0,28 -	0,27 0,23 0,16	0,27 0,23 0,16	0,27 0,23 0,16	0,43 0,37 0,34	0,43 0,37 0,34	0,43 0,37 0,34
		TC45		TC50		TC50d		TC80		TC85		TC85d		TC85				
Peso operativo con pala senza operatore Poids opératif avec pelle sans opérateur	kg kg	505		505		550		600		635		615						
Carico utile sottocarro Charge utile base chenillée	kg kg	500		500		500		800		850		850						
Motore tipo Raffreddamento ad aria Moteur type Refroidissement par air		Benzina Essence Briggs & Stratton 750		Benzina Essence Honda GX200		Diesel Diesel Yanmar L70N6		Benzina Essence Honda GX270		Diesel Diesel Yanmar L100N6		Benzina Essence Honda GX390						
Potenza massima Puissance max	cv/kW	5/3.7		6.5/4.8		6.6/4.9		9/6.6		10/7.4		13/9.6						
Cilindri/cilindrata Cylindres/Cylindrée	n/m³	1/163		1/196		1/320		1/270		1/406		1/389						
Systema idraulico: 3 pompe a ingranaggi Systeme hydraulique: 3 pompes à engrenages		2x12.5 lt/min@ 190 bar 1x14 lt/min@ 135 bar		2x12.5 lt/min@ 190 bar 1x14 lt/min@ 135 bar		2x12.5 lt/min@ 190 bar 1x19 lt/min@ 135 bar		2x20.5 lt/min@ 175 bar 1x20 lt/min@ 150 bar		2x20.5 lt/min@ 175 bar 1x20 lt/min@ 150 bar		2x20.5 lt/min@ 175 bar 1x20 lt/min@ 150 bar						
N. 2 velocità I/II N. 2 vitesses I/II	Km/h	0-1.8/0-3.9		0-1.8/0-3.9		0-1.6/0-5.2		0-2.1/0-4.2		0-2.1/0-4.2		0-2.1/0-4.2						
Pressione specifica al suolo: vuoto/pieno Pression spécifique au sol à vide/en charge	kg/cm² kg/cm²	0.118/0.254		0.118/0.254		0.151/0.240		0.166/0.335		0.190/0.360		0.181/0.350 0.190/0.360						
Pendenza massima superabile a pieno carico Pente max franchissable ne plein charge	% %	30		30		30		30		30		30						
Capacità serbatoio carburante Capacité réservoir carburant	lt lt	3,6		3,6		3,3		6		5,5		6,5						
Capacità serbatoio olio idraulico Capacité réservoir huile hydraulique	lt lt	18		18		18		22		30		30						

dimensioni d'ingombro in mm

dimensiones in mm

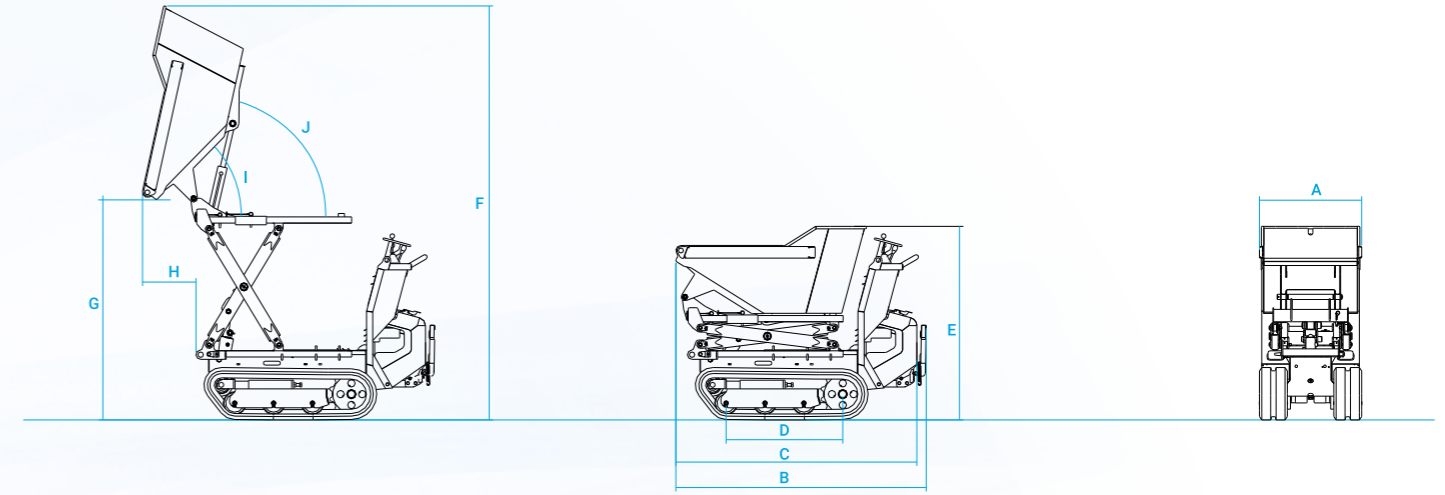

AV	A	B	C	D	E	F	G	H	I	J
TC50	660	1616	1555	753	1249	2671	1423	345	46°	78°
TC50d	660	1616	1555	753	1249	2671	1423	345	46°	78°
TC85d	790	1762	1701	753	1249	2671	1423	345	46°	78°

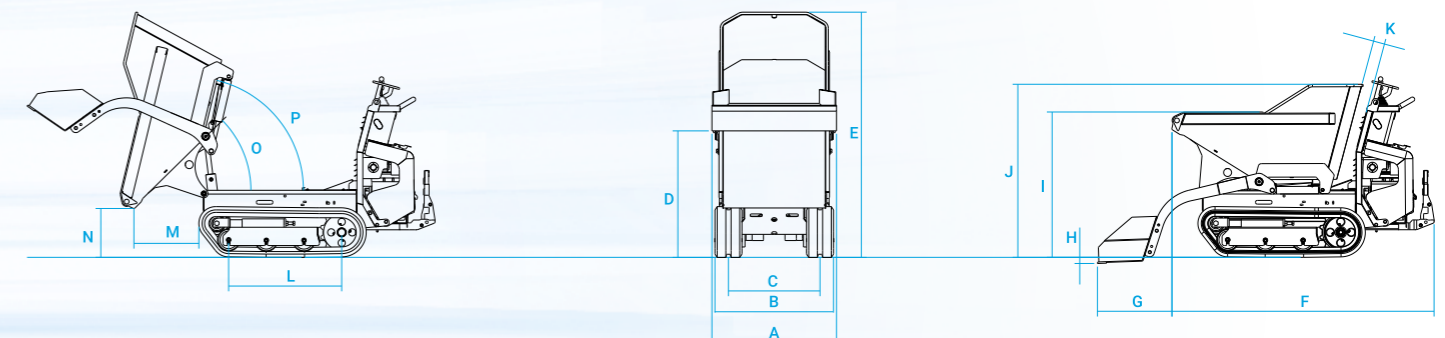

MT - MTP	A	B	C	D	E	F	G	H	I	J	K	L	M	N	O	P
TC45	700	660	480	842	1631	1600	497	41	967	1153	73	753	432	325	45°	76°
TC50	700	660	480	842	1631	1600	497	41	967	1153	73	753	432	325	45°	76°
TC50d	700	660	480	842	1631	1600	497	41	967	1153	73	753	432	325	45°	76°
TC80	830	790	610	842	1633	1746	496	41	967	1152	75	753	432	325	45°	76°
TC85d	830	790	610	842	1633	1746	496	41	967	1152	75	753	432	325	45°	76°
TC85	830	790	610	842	1633	1746	496	41	967	1152	75	753	432	325	45°	76°

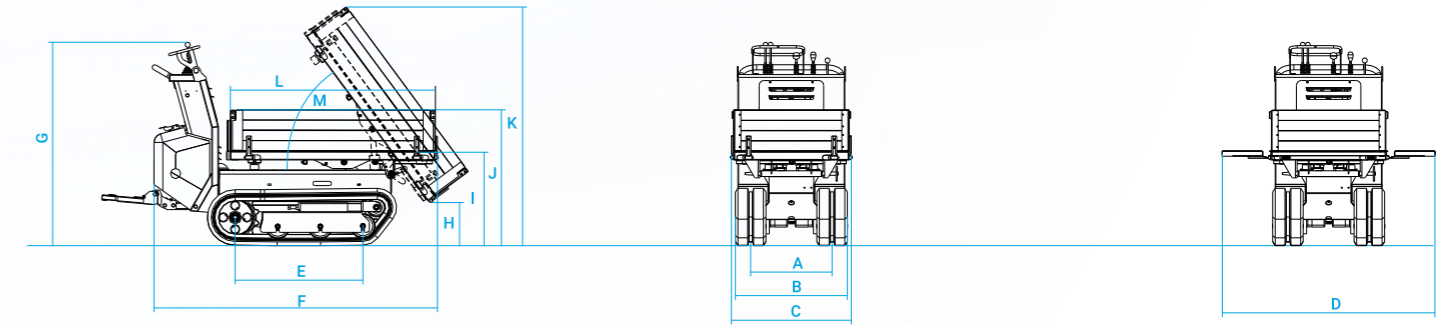

CA	A	B	C	D	E	F	G	H	I	J	K	L	M
TC45	480	660	707	1254	753	1670	1180	225	550	800	1400	1210	53°
TC50	480	660	707	1254	753	1670	1180	225	550	800	1400	1210	53°
TC50d	480	660	707	1254	753	1670	1180	225	550	800	1400	1210	53°
TC80	610	790	840	1390	753	1720	1180	225	550	800	1400	1230	53°
TC85d	610	790	840	1390	753	1720	1180	225	550	800	1400	1230	53°
TC85	610	790	840	1390	753	1720	1180	225	550	800	1400	1230	53°

Dati, caratteristiche ed illustrazioni non sono impegnativi e potranno essere variati senza alcun preavviso. Données, caractéristiques et photos ne sont pas engageants et peuvent être modifiés sans aucun préavis.